

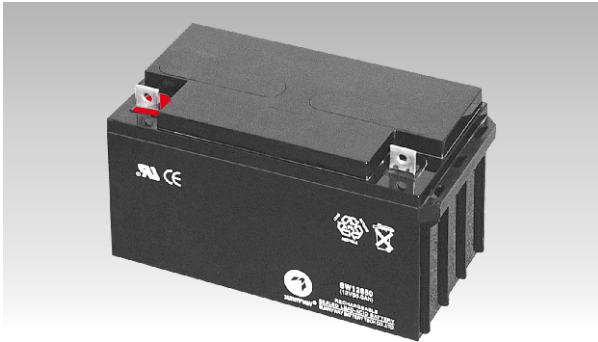

SW12650E(12V65AH)

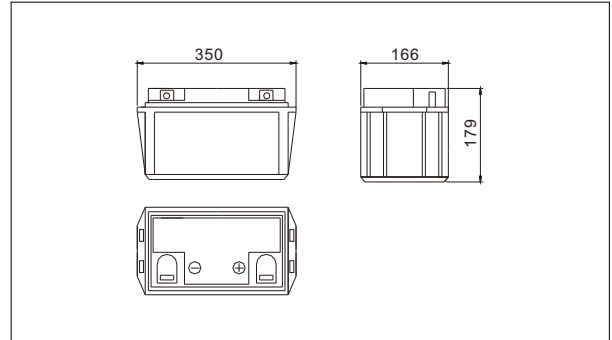

Outer dimensions (mm)



Specifications

Nominal Voltage		12V
Rated capacity (10 hour rate)		65 Ah
Dimensions	Total Height	179 mm (7.05 inches)
	Height	179 mm (7.05 inches)
	Length	350 mm (13.8 inches)
	Width	166mm (6.54 inches)
Weight Approx		21 Kg (46.3 lbs)

Terminal Type (mm)

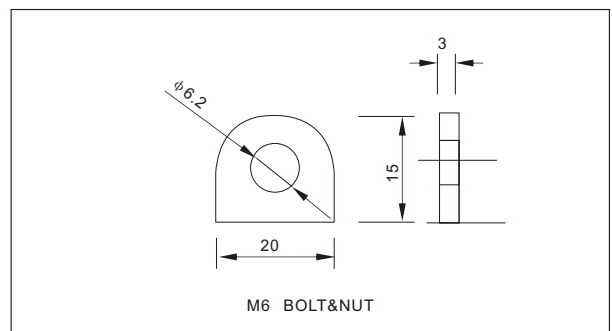

Characteristics

Capacity 25°C(77°F)	10 hour rate(6.5 A)	65 AH
	5 hour rate(10.4 A)	52 AH
	1 hour rate(39.0 A)	39 AH
1.5 hour discharge to 10.5V		26 A
Internal Resistance	Full charged Battery at 25°C(77°F)	5 mΩ
Capacity affected by Temperature (10hour rate)	40°C(104°F)	102%
	25°C(77°F)	100%
	0°C(32°F)	85%
	-15°C(5°F)	65%
Self-Discharge at 25°C(77°F)	Capacity after 3 month storage	91%
	Capacity after 6 month storage	82%
	Capacity after 12 month storage	64%
Terminal		T9、T16
Charge (constant Voltage)	Cycle	Initial Charging Current less than 13 A Voltage 14.20-14.60V
	Float	Voltage 13.50-13.80V

Discharge Curves 25°C(77°F)

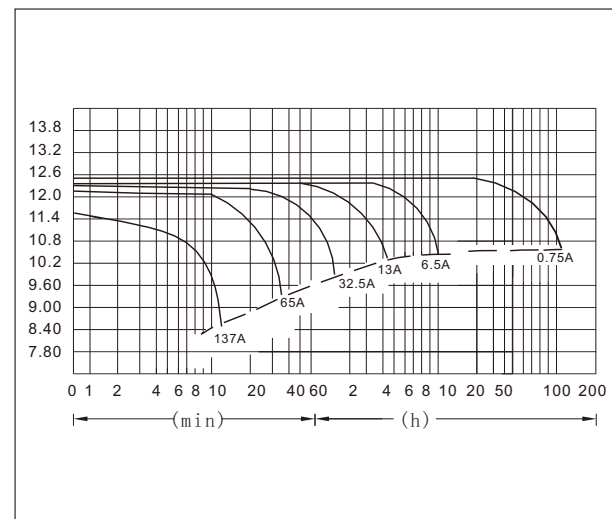

Constant Current(Amp) and Constant Power(Watt) Discharge Table at 25°C(77°F)

Time		10min	30min	1h	3h	4h	5h	8h	10h	20h	50h	100h
9.60V	A	137	74	39	16.7	13.0	10.7	7.6	6.8	3.69	1.53	0.79
	W	1523	794	452	193	151	124	88	79	42.7	18.3	9.4
10.20V	A	133	72	36.7	16.3	12.7	10.5	7.4	6.7	3.59	1.48	0.77
	W	1465	786	425	188	147	122	86	77	41.6	17.6	9.1
10.50V	A	127	69	35	15.9	12.5	10.4	7.3	6.5	3.55	1.46	0.75
	W	1420	742	411	184	145	120	85	76	41.1	17.4	8.9
10.80V	A	119	66	34	15.5	12.3	10.1	7.2	6.3	3.51	1.43	0.74
	W	1364	714	393	180	142	118	83	76	40.9	17.0	8.8
11.10V	A	109	61	32	15.0	11.9	9.9	7.0	6.18	3.33	1.40	0.72
	W	1341	709	383	178	141	118	83	73	39.7	16.7	8.5